

6 5 4 3 2 1

D

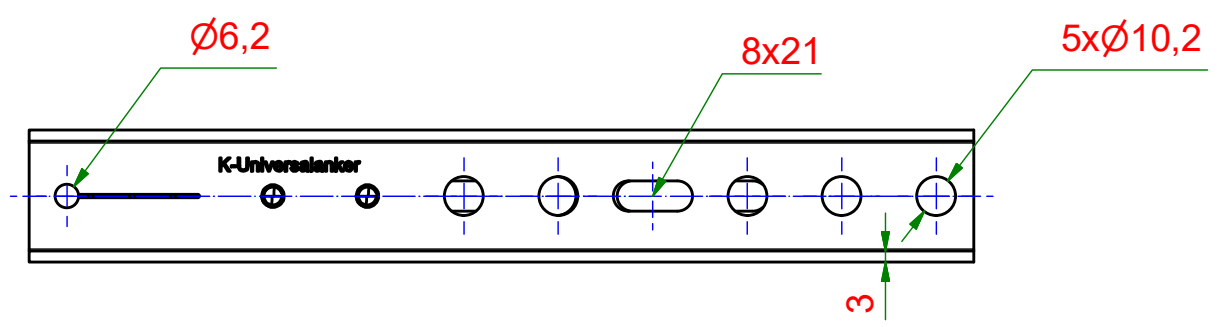

C

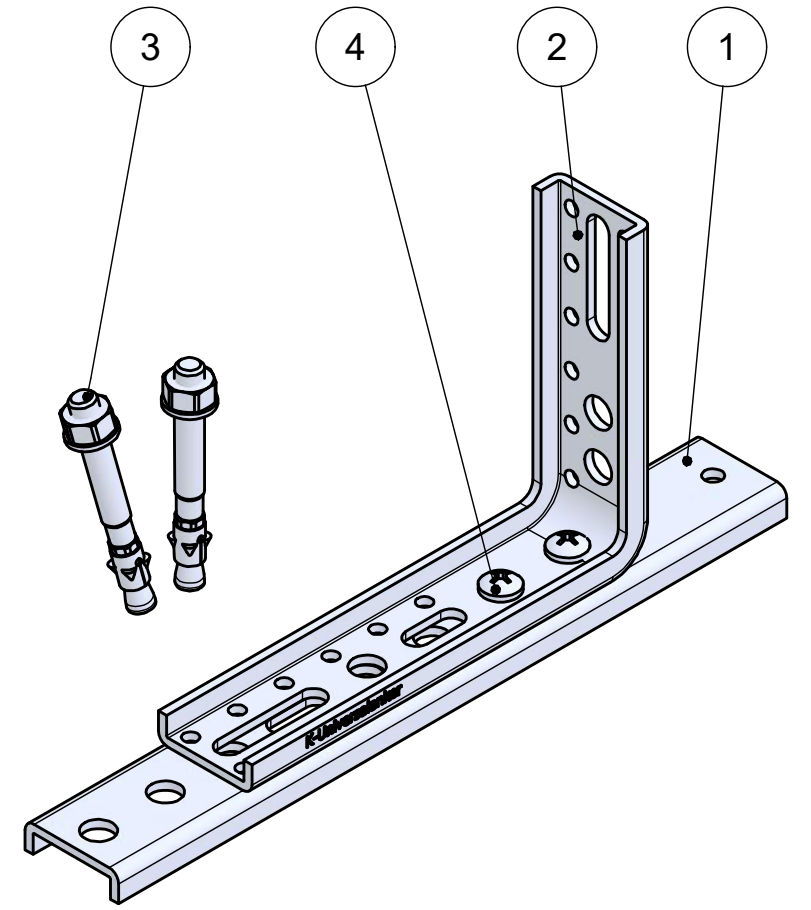
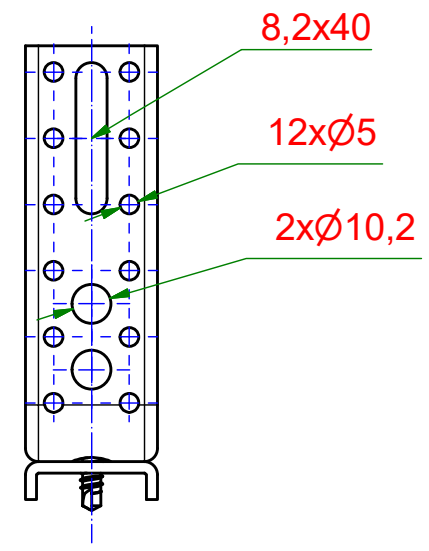
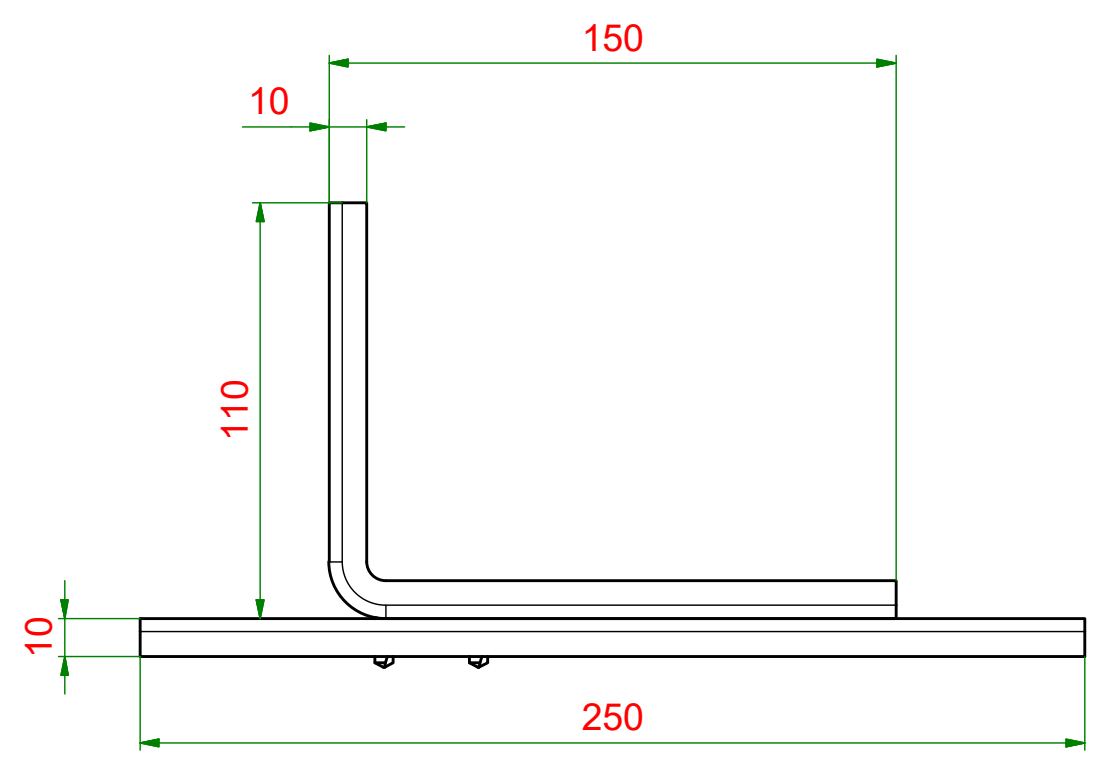

B

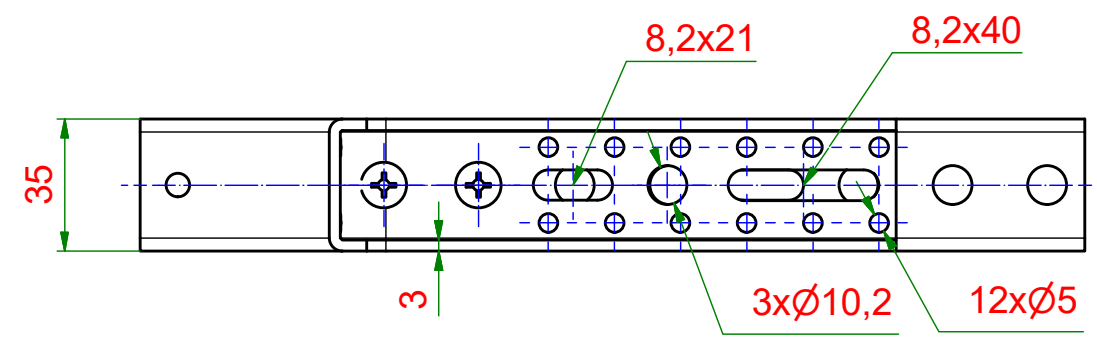

A

Teilleiste			
Pos.	Stk.	Bezeichnung	
1	1	EL-Anker-U-Profil-250x3,0	
2	1	VBW-Verbindungswinkel-110x150x3,0	
3	2	Schwerlastdübel-Ø8x71	
4	2	Bohrschraube_6,3x16_DIN_7504	

<b>KNELSEN</b> Entwicklung und Herstellung  Knelsen GmbH Am Schlinge 26 33154 Salzkotten Tel.: 05258 / 93766-95 Fax: 05258 / 93766-97 www.knelsen.de info@knelsen.de		Material: verzinkter Stahl		
		Maßstab: 1 : 2		Masse: 0,6 kg
	Datum: _____ Name: _____ Erstellt: 27.02.2019 R.Heiermeier Genehmigt: _____		Titel, Beschreibung <b>BAP-SLK-250 U110x150</b> BAP-Schwerlastkonsole	
	Allgemeintoleranzen nach ISO 2768-m Schutzvermerk nach DIN ISO 16016 beachten		Bauteilnummer / Zeichnungsnummer <b>405211</b>	

D

C

B

A

6 5 4 3 2 1